

OPTIMUS® TRANSPORT PACKAGINGS

HIGHLIGHTS

- Versatile, cost-effective Type B(U)F Packaging for Intermediate Level Waste (ILW), Transuranic (TRU) Waste, Low-Enriched Uranium (LEU), High-Assay LEU (HALEU), and spent fuel
- Two package types (OPTIMUS-L & -H) for low-activity and high-activity contents
- Ships challenging waste, such as high-activity sealed sources, over-packed containers with high heat loads, and aerosol cans with compressed or liquified gas propellant
- Use of same Cask Containment Vessel (CCV) design and Shield Insert Assemblies in both OPTIMUS-L & -H packages allow interchangeability and standardization of operating procedures
- Easily reconfigured with shield inserts for contents requiring increased activity shielding
- Small, light packages ideal for facilities with restricted access and/or low crane capacity
- Pallets allow forklift handling to simplify loading and unloading operations



OPTIMUS-L



OPTIMUS-H

OPTIMUS shipping casks are designed to support legal weight truck (LWT) shipments of a wide range of wastes and fissile material contents in multiple transport configurations.

- Up to 6 OPTIMUS-L packagings per legal-weight truck shipment
- Up to 2 OPTIMUS-H packagings per legal-weight truck shipment

SIA	OPTIMUS-H	OPTIMUS-L
1"	✓	✓
2 ¼"	✓	✓
3 ¾"	✓	—

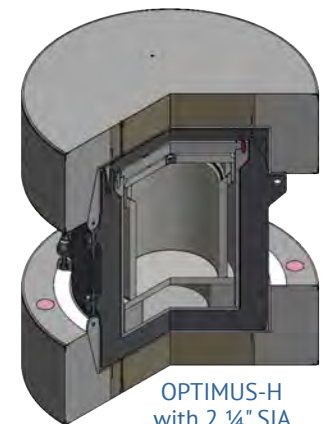

OPTIMUS-H with 2 ¼" SIA

NAC International is transforming radioactive materials (RAM) transportation packaging with its patented OPTIMUS systems; a new family of Type B(U)F transportation packagings developed for transportation of challenging materials. OPTIMUS-L is used for low-activity contents such as CH-TRU, low-activity ILW, LEU, and HALEU; OPTIMUS-H is used for high-activity contents including RH-TRU, high-activity ILW, and spent fuel.

OPTIMUS provides a transportation solution for challenging contents, such as overpacked containers (e.g., 110-gallon drums) with high heat loads or fissile gram equivalent (FGE) content, gas generating materials, and TRU waste including aerosol cans filled with compressed or liquified gas propellant.

OPTIMUS transportation packagings are designed to satisfy the regulatory requirements of both IAEA SSR-6 and 10CFR71.

Large cavity and high payload weight limit allows OPTIMUS packaging to be reconfigured with Shield Insert Assemblies (SIAs), balancing weight and shielding constraints.



PACKAGING COMPONENT DESCRIPTION

CASK CONTAINMENT VESSEL (CCV)

- Stainless steel containment vessel
- Innovative bolted closure system to facilitate remote closure operations
- Universal and compatible lifting and anchoring attachments
- The CCV is designed to be interchangeable for use in both the OPTIMUS-L and OPTIMUS-H

OUTER SHIELD VESSEL (OSV)

- Cost-effective shield vessel to protect CCV
- Simplified mechanical closure with weather seal
- Integral trunnions, tie downs and attachment lugs for efficient handling
- Integrated drain and monitoring port

IMPACT LIMITER SYSTEM (ILS)

- Closed-cell polyurethane foam encased in stainless steel
- Swing-bolt connections for quick installation/removal

SAFETY BY DESIGN FEATURES

- 10CFR71 & SSR-6 Type B(U)F compliant
- Designed to ASME Code Section III-NB and NF criteria
- Pressurization analysis
- Contingency combustion analysis, considering possible deflagration and detonation
- Up to 395 FGE per drum for plutonium and uranium wastes

CONTACT:

Mike Valenzano, Director,
Transportation Projects
Phone: +1 678-328-1213
mvalenzano@nacintl.com



Kanadevia Group

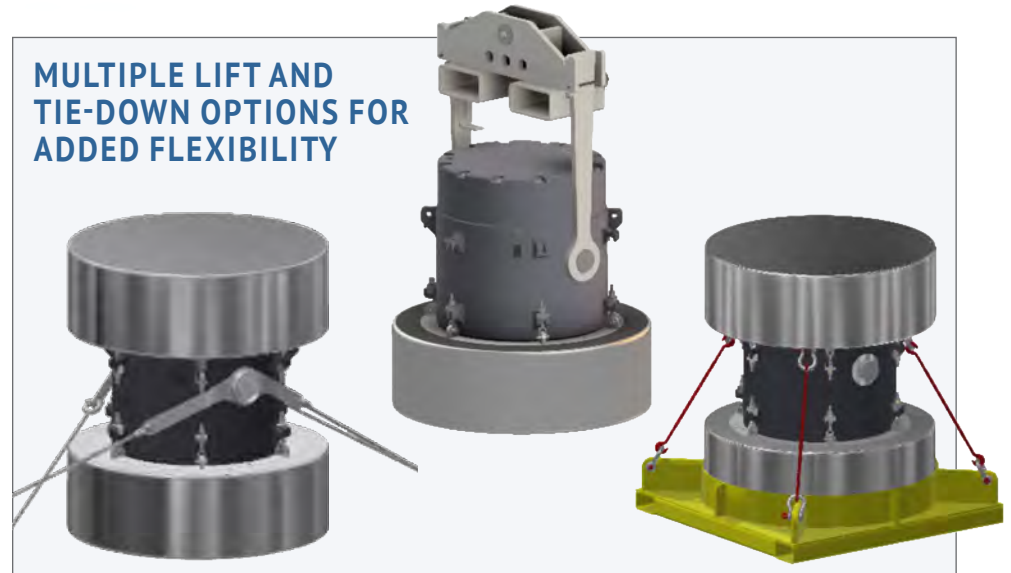
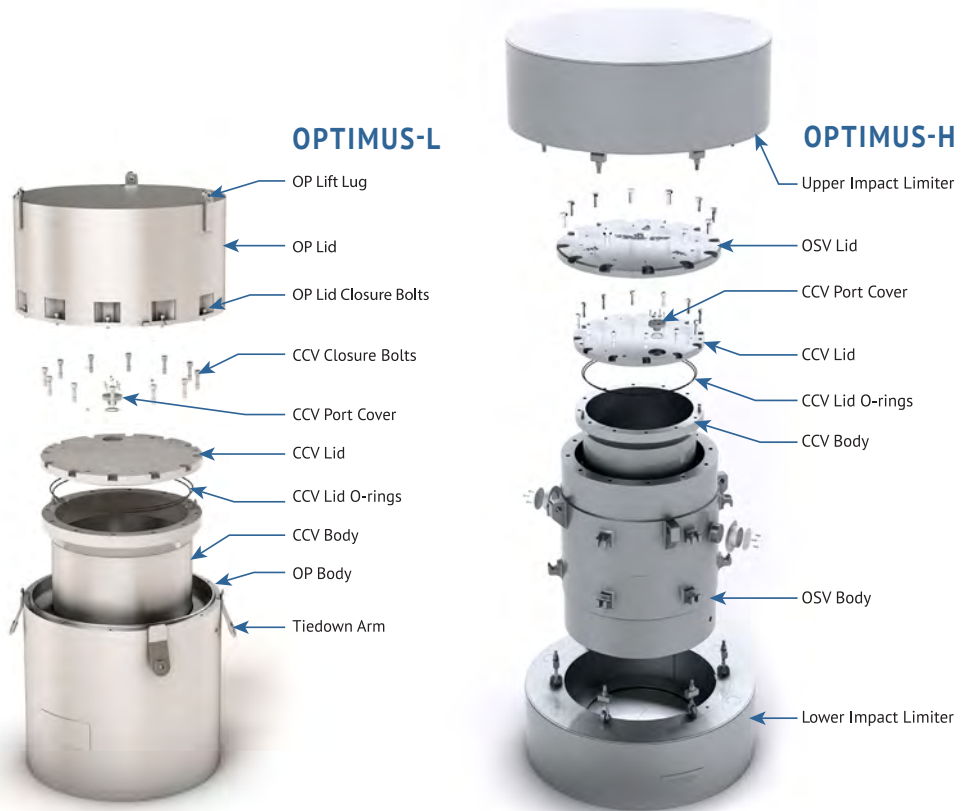

PACKAGING ATTRIBUTE	OPTIMUS-H	OPTIMUS-L
Package ID Number	USA/9392/B(U)F-96	USA/9390/B(U)F-96
Controls	Exclusive Use	
Cavity Size (in.)	Ø32.5 x 47.0 (fits 110 Gallon Drum)	
MNOP (psig)	100	
Outer Dimensions (in.)	Ø74.2 x 83.2	Ø49.0 x 70.0
Empty Weight (lb.)	24,700	6,050
Maximum Content Weight (lb.)	7,300	3,150
Gross Weight (lb.)	~25,000 to 32,000	~6,500 to 9,200